

Atlas Lighting Supply

2828 S. Linwood St

Visalia, CA 93277

Ph: 559-804-1664, F: 888-605-2324

www.atlaslightingsupply.com

Date: 12/1/2009

2 Year Warranty

Catalog#	BB-1000HPC6CC
Type:	1000W High Pressure Sodium
Voltage:	5 Tap(120/208/240/277/480)

General Information

Lamp Type	1000W HPS
ANSI Designation	S52
Line Voltage(V)	120/208/240/277/480
Regulation	10%
Frequency(Hz)	60
Recommended Fuse(A)	20/15/10/10/8
Circuit Type	CWA
Insulation Class	180°C
Capacitor Value	26 UF
Capacitor Voltage Rating	525V
Cap.Temp.Rating	90°C
Winding Materials(Pri/Sec)	Al/Al
Lamp Starter	BI-803
Agency Certification	RU,cRU
Maximum Distance to Lamp	2FT

Wiring Diagram

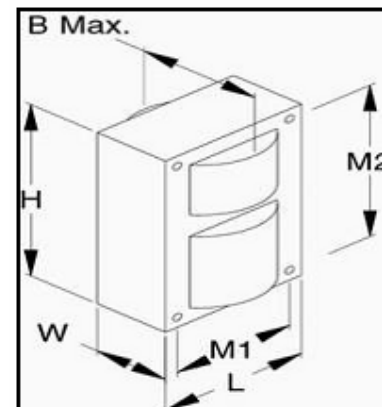
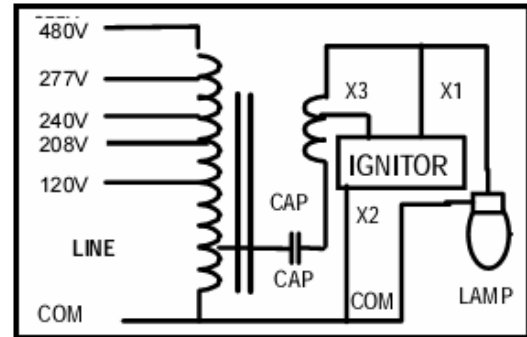

Electrical Characteristics

Line Volt (V)	Power Factor	Line Current (A)			Input Power (W)	Open Circuit Voltage (V)	Min Start Temp.
		Operating	Open	Start			
120	High	9.50	5.27	5.75	1080	443	-40°C
208	High	5.30	3.11	3.40	1080	443	-40°C
240	High	4.80	2.71	2.90	1080	443	-40°C
277	High	4.30	2.35	2.60	1080	443	-40°C
480	High	2.50	1.35	1.80	1080	443	-40°C

Physical Characteristics

Overall Dimensions (Inches)				Mounting Holes (Inches)			Bracket Dimension (Inches)		Ballast Net Weight (KG)	Lead Length (Inches)
Length	Width	Height	B max.	Diameter	M1	M2	Length	Width		
4.30	4.33	6.02	6.28	0.25	3.89	5.37	7.25	1.11	12.35	12-14